

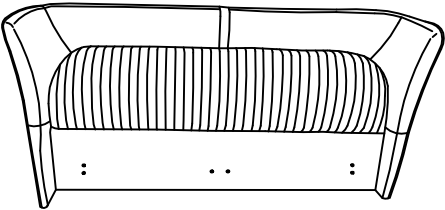
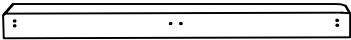

Assembly Instruction

**组装说明书**

Number	Parts Identification		Quantities
编号	部件明细		数量
A		Headboard 床头	1
B		Footboard 床尾	1
C	 Side Rail	床侧	2
D	 Middle Slat	床中连杆	1
E		Slat 床铺板	1

Number	Hardware List		Quantities
编号	五金明细		数量
1		螺杆 Big Screw	40
2		木螺丝 Small Screw	8
3		Footboard & Side Rail Support 底脚	4
4		L-shaped angle Bracket L 型角铁	4
5		U-shaped angle Bracket U 型角铁	2
6		Adjustable support feet 可调节支撑脚	2

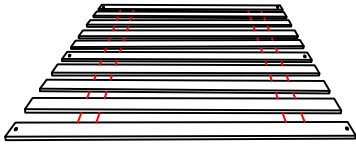
# 步骤1:

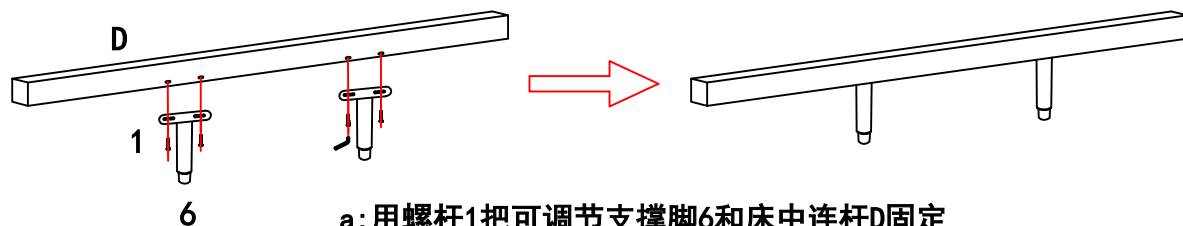

**a: 用螺杆1把可调节支撑脚6和床中连杆D固定**  
a: Use the Big Screw ① to secure the Adjustable support feet ⑥ to the Middle Slat[D].

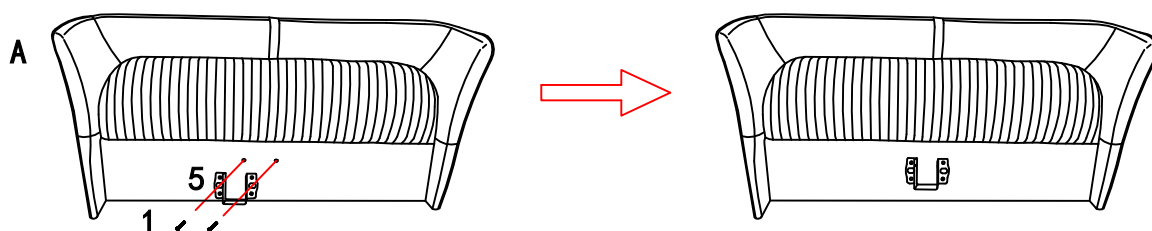

**b: 用螺杆1把U型角铁固定6固定在床头A上（位置图示）**  
b: Use the Big Screw ① to secure the U-shaped angle Bracket ⑤ to the Headboard[A](Location as in Pic)

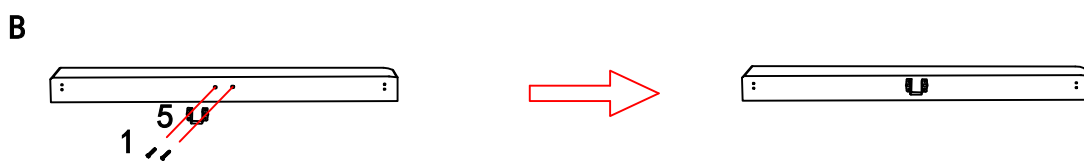

**c: 用螺杆1把U型角铁固定6固定在床尾B上（位置图示）**  
c: Use the Big Screw ① to secure the U-shaped angle Bracket ⑤ to the Footboard[B](Location as in Pic)



**d: 用螺杆1把L型角铁固定4固定在床侧C上（位置图示，注意L型角铁上下可调节长槽留给床头，床尾安装螺杆用）**  
d: Use the Big Screw ① to secure the L-shaped angle Bracket ④ to the Side Rail[C](Location as in Pic)  
Note that the long upper and lower adjustable slots in the L-shaped angle Bracket ④ are reserved for mounting Big Screw ① to properly align the Footboard[B] and the Side Rail[C].

## 步骤2:

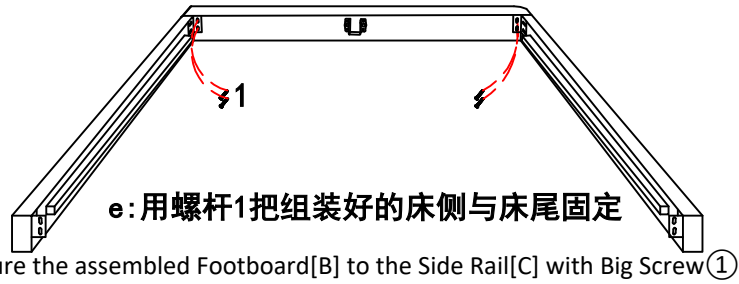

e: 用螺杆1把组装好的床侧与床尾固定

e: Secure the assembled Footboard [B] to the Side Rail [C] with Big Screw ①

f: Secure the Footboard & Side Rail Support ③ to the assembled footboard [B] and side rails [C] with Big Screw ①.

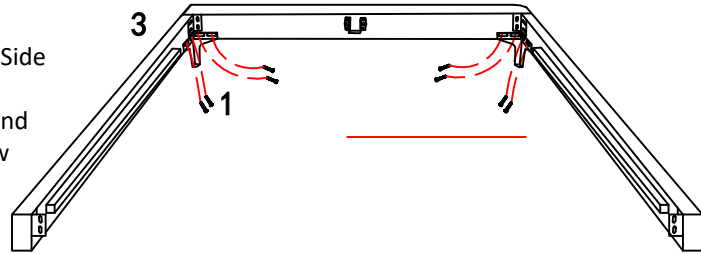

f: 用螺杆1把底脚固定在组装好的床侧与床尾上

## 步骤3:

g: 用螺杆1把床侧与床头固定

g: Secure the Side Rail [C] and Headboard [A] with Big Screw ①.

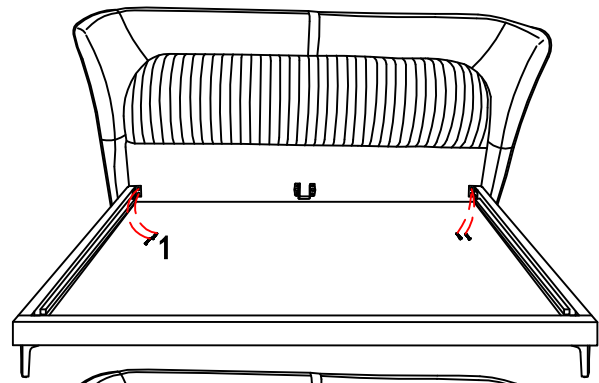

h: 1, 用螺杆1把底脚固定在床侧与床头上  
2, 把组装好的床中连杆放入U型角铁内  
用2个木螺丝锁住

h: 1. Secure the Footboard & Side Rail Support ③ to the Headboard [A] and side rails [C] with Big Screw ①.

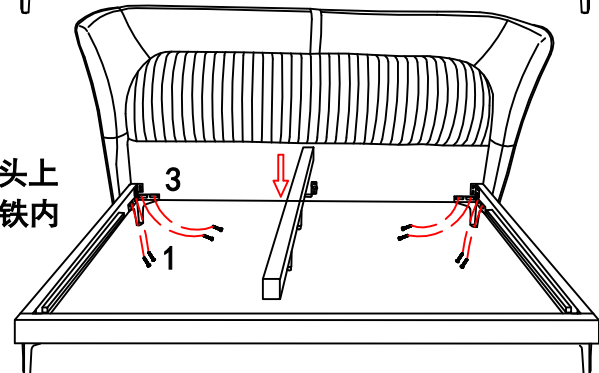

## 步骤4:

h: 2. Put the assembled Middle Slat [D] into the U-shaped angle Bracket ⑤ and lock it with 2 Small Screws ②.

i: 用木螺丝把床铺板（绷带固定好）固定

i: Secure the Slat [F] (bandage secured) with Small Screws ②.

